

AGER SERIES SIDE- AND HIGHBOARDS

PBJ
DESIGNHOUSE
EST. 1968



AGER sideboard and glass cabinets are designed by René Hougaard – Arde design. The classical furniture in the AGER series is developed on the base of good craftsmanship and includes a number of very nice design details that reflects the high quality of the furniture.

www.pbjdesignhouse.com

*Designed by
René Hougaard*





AGER sideboard

No 13615443043

L 154 W 45 H 71 cm.

No 13620043043

L 205 W 45 H 72 cm.

Sideboard with 2 or 3 doors and 2 drawers. 1 shelf behind each door.

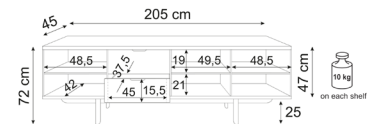

AGER low glass cabinet

No 13615043043

Cabinet with 3 tempered glass doors. 2 wooden shelves behind each door, incl. LED light.

L 154 W 45 H 117 cm.

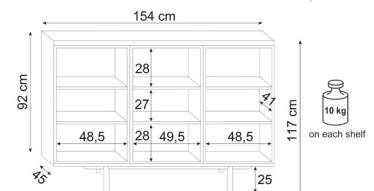

AGER high glass cabinet

No 13620043043

Cabinet with 2 tempered glass doors. 4 wooden shelves behind each door, incl. LED light.

L 103 W 45 H 188 cm.

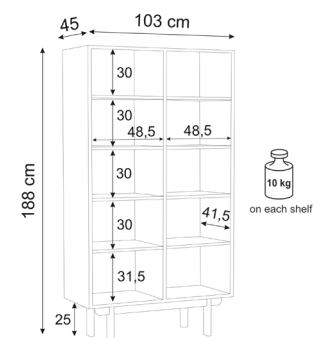

AGER SERIES

The sideboards and the small glass highboard of the Ager series have a beautiful tray detail on the top. All 4 cabinets come with solid wooden adjustable oak legs. The doors have self-closing hinges, drawers with full extension and self-closing mechanism. The glass cabinets have LED light functionality with on/off sensor and dimmer. The series are available in light oak lac.



COLOURS AND MATERIALS

BASE, FRAME AND CABINET

VENEER



43 Light oak
mat lac

DOORS AND DRAWERS

VENEER



43 Light oak
mat lac

QUALITY FURNITURE SINCE 1968

PBJ Designhouse was founded in 1968 by Per Buhl Jørgensen. Since 1996 the proud design and craftsmanship tradition has been carried on by Morten Svendsen, and the company has invested in larger production facilities to follow the strong demand.

DANISH DESIGN

PBJ Designhouse has a tradition of bringing together furniture architects and certified cabinet makers since the start.

This has turned the company into an exponent of Denmark's proud traditions in furniture – when creativity and quality unite, the result reaches new heights.

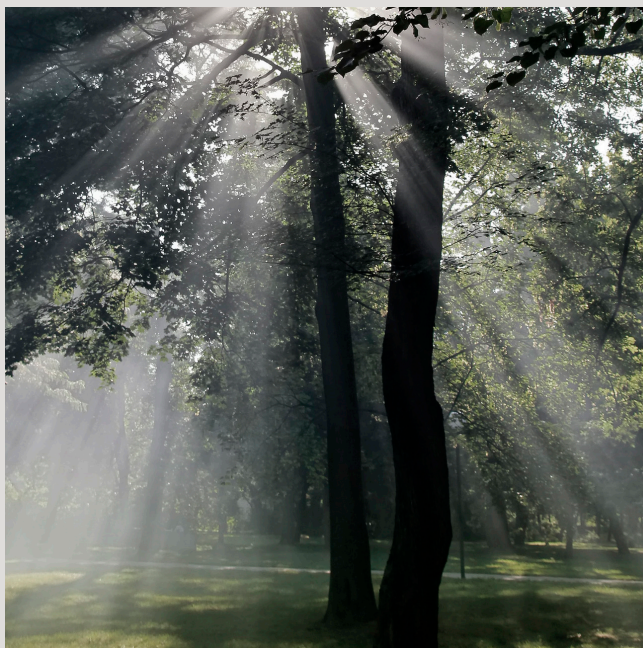

FURNITURE WITH A CONSCIENCE

All wood used at PBJ Designhouse comes from state approved plantations, where the logs are individually selected and gently harvested.

We often produce furniture with veneer. The reason for this is twofold. It reduces the use of solid timber, thereby conserving natural resources. Secondly, the MDF that the veneer cover is made with recycled wood which is better for the environment whilst still producing a strong and high-quality surface.

All of our timber and veneer are carefully hand sorted so that the grain patterns and color variations are as natural as possible.



PBJ Designhouse
Skovvænget 2
DK-7860 Spøttrup
Denmark

pbj@pbjdesignhouse.com
pbjdesignhouse.com

Item: 0010-0002 - Version: 04012022

Your specialist dealer:

The brochure is subject to technical changes and possible printing errors.