



# OCULUS SERIES SIDEBOARD-HIGHBOARD

**Oculus sideboard, designed by Morten Svendsen.** The Oculus series consists of veneered cabinets with mitre joints and rounded front edges. The cabinet comes in 7 combinations and 3(4) colours. The doors have self-closing hinges and the drawers have full extension and self-closing mechanism. Inside there are dividers and/or shelves, and the back is fully veneered, so it can be free standing. The sideboards comes with massive round legs, that almost gives the series a flying look. The Multi Highboard always comes with Dark warm grey fenix on the back of the flap. The Glass Highboard comes with 2 glass shelves, and 2 wooden shelves and LED light functionality with on/off sensor and dimmer. All sideboards and highboards comes with adjustable feet. Selected cabinets can be chosen in Smoked oak, with either Smoked oak or Fenix fronts. These cabinets are marked with ## inside this brochure.



*Designed by Morten Svendsen*



**Oculus Glass Highboard**  
 2 doors w/tempered glass and wood.  
 No 138090  
 L 91 D 45 H 204 cm.

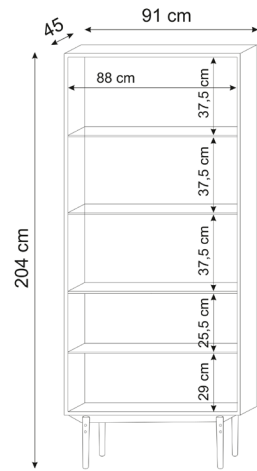

**#Oculus Highboard**  
 3 doors + 3 drawers  
 No 138110  
 L 110 D 40 H 138 cm.

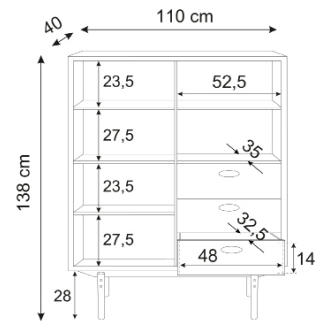

**Oculus Multi Highboard**  
 3 doors + 2 drawers + 1 flap. Flap  
 always Dark warm grey fenix inside.  
 No 138133  
 L 133 D 40 H 120 cm.

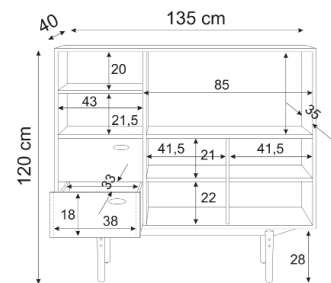

**#Oculus Sideboard**  
 1 door + 3 drawers  
 No 138120  
 L 118 D 45 H 75 cm.

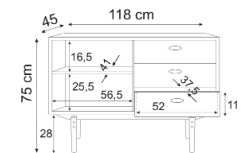

**#Oculus Sideboard**  
 2 doors + 3 drawers  
 No 138176  
 L 176 D 45 H 75 cm.

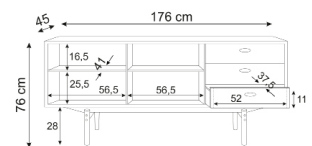



### Oculus Sideboard

3 doors + 3 drawers  
No 138233

L 233 D 45 H 75 cm.

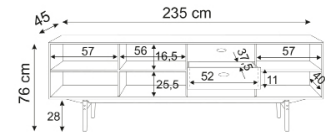

### Oculus Lowboard

2 doors + 1 flap  
No 238232

L 233 D 45 H 52 cm.

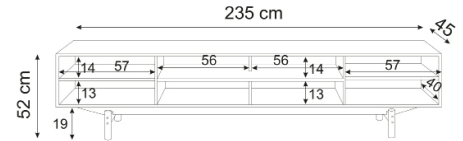

## INSPIRATION



## COLOURS AND MATERIALS

### BASE, \*FRAME AND \*CABINET

SOLID/\*VENEER: 43 Light oak mat lac 75 Walnut oil 87 Black oak mat lac 49 Smoked oak mat lac

SMOKED OAK ONLY ON SELECTED CABINETS - WITH SMOKED OAK OR FENIX FRONT - MARKED WITH ##

### DOORS AND DRAWERS

VENEER: 43 Light oak mat lacquer 75 Walnut 87 Black oak 49 Smoked oak mat lac

HPL LAMINAT: 101 White 107 Aqua-marine 110 Seed 113 Dusty Jade 128 Earth

131 Storm 134 Terril 184 Nero Stone HPL

FENIX (NANO) LAMINATE: 201 Bianco White 204 Deep Black 202 Efeso 210 Dark Warm Grey 231 Blue Fes

219 Verde 222 Grigio 225 Cacao 228 Rosso

LINOLEUM: 438 Smokey Blue 442 Olive 434 Black 436 Pewter 445 Mauve



## QUALITY FURNITURE SINCE 1968

PBJ Designhouse was founded in 1968 by Per Buhl Jørgensen. Since 1996 the proud design and craftsmanship tradition has been carried on by Morten Svendsen, and the company has invested in large production facilities to follow the strong demand.

## DANISH DESIGN

PBJ Designhouse has a tradition of bringing together furniture architects and certified cabinet makers since the start.

This has turned the company into an exponent of Denmark's proud traditions in furniture – when creativity and quality unite, the result reaches new heights.



## FURNITURE WITH A CONSCIENCE

All wood used at PBJ Designhouse comes from state approved plantations, where the logs are individually selected and gently harvested.

We often produce furniture with veneer. The reason for this is twofold. It reduces the use of solid timber, thereby conserving natural resources. Secondly, the MDF that the veneer cover is made with recycled wood which is better for the environment whilst still producing a strong and high-quality surface.

All of our timber and veneer are carefully hand sorted so that the grain patterns and colour variations are as harmonious as possible.



### Sales

Name

Title

E-mail:

Tel:

### PBJ Designhouse

Skovvænget 2

DK-7860 Spøttrup

Denmark

E-mail: [pbj@pbjdesignhouse.com](mailto:pbj@pbjdesignhouse.com)

[www.pbjdesignhouse.com](http://www.pbjdesignhouse.com)

Item: 0010-0025 - Version: 25-08-2021

Your  
Specialist  
Dealer:

*The brochure is subject to technical changes and possible printing errors.*